

22/130

The weldable Clip

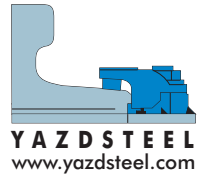

The (GANATREX DESIGNE) 22/130 adjustable crane rail clip is designed to fix heavy rails in the most arduous applications, it can Withstand ahorizontal force from the rail of 130 KN(13 tonnes) The clip can be use for rail type: A65,A75,Qu70,Qu80, Qu100,UIC54, UIC60...

For more Information Please See next page.



COMPONENTS

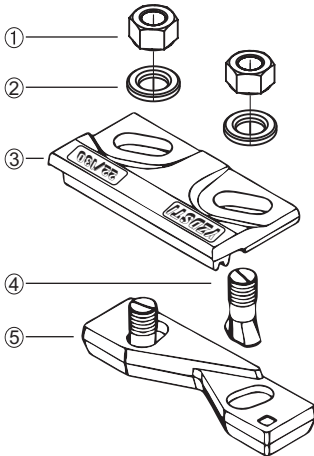

FEATURES

- 1 - M16 hexagon NUT Cl.8
- 2 - M16 hardened flat washer DIN 6919
- 3 - upper part material: ductile cast iron ASTM A 536
- 4 - M16 conical head bolt 8.8
- 5 - lower part material: Forged steel S275JR

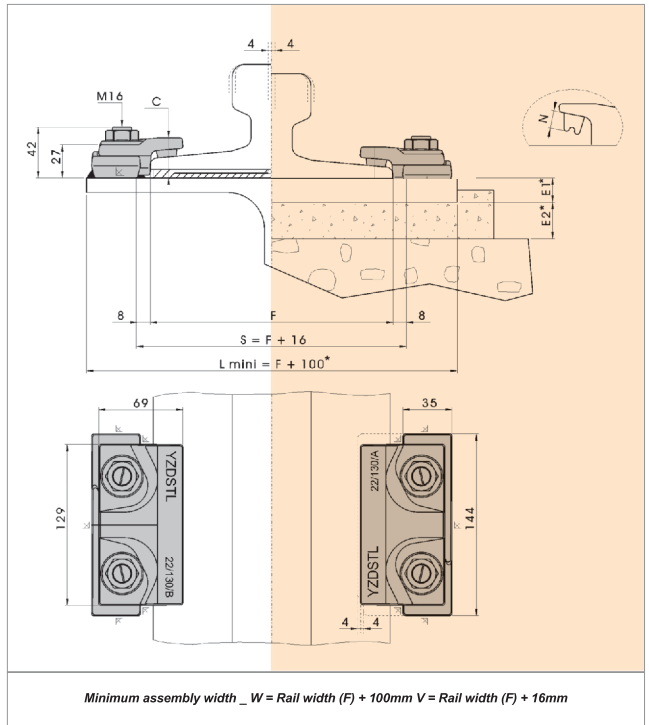

- The two main parts are locked Together on tightening
- The clip has a self-tightening mechanism.
- A special vulcanised rubber block applies a controlled force To the rail.

CLIPS	C MAX (mm)	Tightening torque (Nm)	Admissible side load (KN)	Est,d weight (Kg)
22/130/A	33	125	130	1.450
22/130/B	43			1.550

جدول انتخاب کلمپ بر اساس بکارگیری یا عدم بکارگیری پدهای زیر ریل

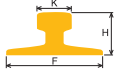
CLIP SELECTION FOR EACH RAIL						
	F mm	K mm	H mm	Weight kg/m	Mounting	
					with	without
					pad	
A 65	175.0	65.0	75.0	43.10	22/130/BQ	22/130/AM
A 75	200.0	75.0	85.0	56.20	22/130/BQ	22/130/AM
A 100	200.0	100.0	95.0	74.30	22/130/BM	22/130/AM
A 120	220.0	120.0	105.0	100.00	22/130/BJ	22/130/AJ
A 150	220.0	150.0	150.0	150.30	22/130/BJ	-
S 49	125.0	67.0	149.0	49.43	22/130/BM	22/130/AM
S 54	125.0	67.0	154.0	54.54	22/130/BM	22/130/AM
S 64	150.0	74.0	172.0	64.92	22/130/BM	22/130/AJ
EB 50 T	140.0	72.0	151.0	50.10	22/130/BM	22/130/AM
UIC 54	140.0	70.0	159.0	54.43	22/130/BQ	22/130/AM
UIC 60	150.0	72.0	172.0	60.34	22/130/BM	22/130/AM
56 CR	171.0	76.0	101.5	56.81	22/130/BM	22/130/AM
BS 113 A	139.7	69.9	158.8	56.40	22/130/BM	22/130/AM
JIS 37	122.2	62.7	122.2	37.20	22/130/BQ	22/130/AQ
JIS 50 N	127.0	65.0	153.0	50.40	22/130/BM	22/130/AM
JIS 60	145.0	65.0	174.0	60.80	22/130/BM	22/130/AJ
CR 73	140.0	100.0	135.0	73.30	22/130/BJ	22/130/AJ

INSTALLATION INSTRUCTIONS:

Weld all round the clip base, except the side closest and parallel to the rail, with a 5mm throat thickness fillet weld, using low hydrogen electrodes.

Recommended electrodes AWS E7018 or E 6013. Clip base is made from weldable grade steel.

if a continuous weld around the clip base is required , this is possible.

WELD DETAIL

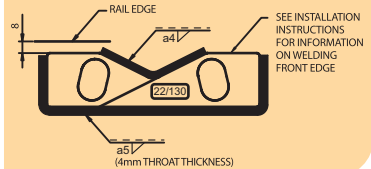

فاصله بین کلمپها بر اساس ماکزیم نیروهای جانبی حداقل ۴ سانتی متر
و حداکثر ۶ سانتی متر توصیه می گردد.
کلیه محصولات ایزد استیل به مدت ۱۸ ماه از زمان نصب تحت شرایط استاندارد دارای گارانتی می باشند